

iT0900 Ice Cube Machine

Model:

- IRT0900A
 IRT0900W

- IDT0900A
 IDT0900W

- IYT0900A
 IYT0900W



Indigo NXT Series iT0900 Ice Machine on a D570 Bin

Designed for operators who know that ice is critical to their business, the Indigo[®]NXT Series ice machine's preventative diagnostics continually monitor itself for reliable ice production. Improvements in cleanability and programmability make your ice machine easy to own and less expensive to operate.

- **easyTouch[®] Display**- New icon based touch screen takes the guess work out of owning and operating an ice machine.
- **Programmable Ice Production** – Now its super easy to program your ice machine to be off at certain times of the day to save money with fluctuating electrical rates. Also programmable by daily ice production volume.
- **Easy to Clean Foodzone** – Hinged front door swings out for easy access. Removable water-trough, distribution tube, curtain, and sensing probes for fast and efficient cleaning. Select components made with AlphaSan[®] antimicrobial.
- **Intelligent Diagnostics** – provide 24 hour preventative maintenance and diagnostic feedback for trouble free operation.
- **Acoustical Ice Sensing Probe** – Unique patented technology allows for reliable operation in challenging water conditions and environments.
- **DuraTech[™] Exterior** – provides superior corrosion resistant above stainless steel. Innovative clear-coat resists fingerprints and dirt making it easier to keep clean.
- **Available LuminIce II Growth Inhibitor**- Controls the growth of bacteria and yeast with the food zone keep the machine cleaner longer. A new indicator in the display keeps you abreast of the operational status.
- **Active Sense**- Insures consistent ice harvest in all environmental conditions. This software and/or hardware solution works in conjunction with the acoustical ice sensing probe improving reliability and performance.

Specifications

BTU Per Hour:

12,700 (average)
 14,800 (peak)

Refrigerant:

R410A CFC free

48% less Global Warming Potential

Operating Limits:

Ambient Temperature Range:
 40 to 100 F (4.4 to 43.3 C)

Water Temperature Range:
 40 to 90 F (4.4 to 32.2 C)

Water Pressure Ice Maker Water In:

Min. 20 psi (137.9 kPa)
 Max. 80 psi (551.1 kPa)

Ice Machine Electric

208-230/60/1
 (230/50/1 also available)

Minimum circuit ampacity:

Air-cooled: 9.5 1ph
 Water-cooled: 8.8 1ph

Maximum fuse size:

Air-cooled: 15 1ph
 Water-cooled: 15 1ph



Ice Shape

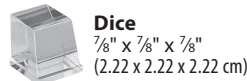
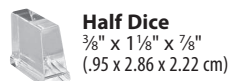

COMPANY WITH QUALITY SYSTEM CERTIFIED BY DNV = ISO 9001:2015 =

iT0900 Ice Cube Machine



iT0900 on D-570 Storage Bin

- Ⓐ Electrical Entrance (2) Options
- Ⓑ 3/8" (0.95 cm) F.P.T. Water Condenser Inlet (water-cooled units)
- Ⓒ 1/2" (1.27 cm) F.P.T. Water Condenser Outlet (water-cooled units)
- Ⓓ 1/2" (1.27 cm) Auxillary Base Drain Socket
- Ⓔ 3/8" (0.95 cm) F.P.T. Ice Making Water Inlet
- Ⓕ 1/2" (1.27 cm) F.P.T. Ice Making Water Drain
- Ⓖ 3/4" (1.91 cm) Bin Drain

Installation Note

Minimum installation clearance:

Top/sides: 8" (20.32 cm);
Back is 5" (12.7 cm)

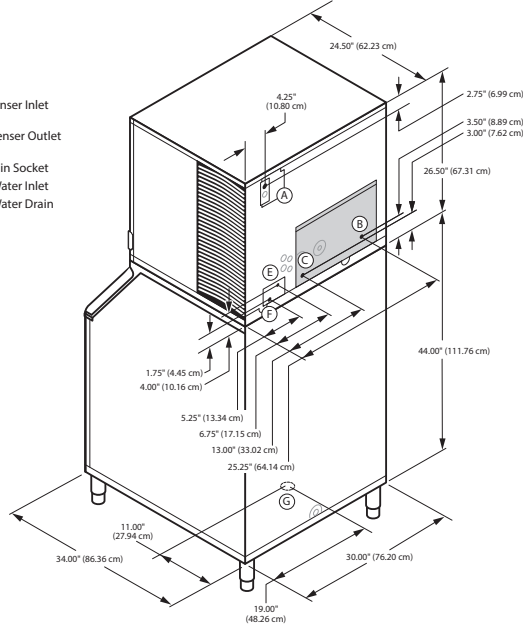

Space-Saving Designs



	iT0900 D-570	iT0900 D-970
Height	76.50" 194.30 cm	76.50" 194.30 cm
Width	30.00" 76.20 cm	30.00" 76.20 cm
Depth	34.00" 86.30 cm	34.00" 86.30 cm
Bin Storage	365 lbs. 165.7 kgs	543 lbs. 241.1 kgs

Height includes adjustable bin legs 6.00" to 8.00", (15.24 to 20.32 cm) set at 6.00" (15.24 cm).
Bin capacity is based on 90% of the volume x 33 lbs/ft³ average density of ice

Specifications

	Model	Ice Shape	Ice Production 24 Hours				Power Usage kWh/100 lbs.@90°Air/70°F	Water Usage/100 lbs. 45.4 kgs. of Ice		ENERGY STAR
			70°Air/ 50°F Water	90°Air/ 70°F Water	1 Ph	Potable Water				
AIR-COOLED	IRT0900A	regular	797 lbs	362 kg	676 lbs	307 kg	5.01	19 Gal.	71.9 L	NA
	IDT0900A	dice	851 lbs	386 kg	695 lbs	315 kg	4.85	19 Gal.	71.9 L	★
	IYT0900A	half-dice	865 lbs	392 kg	750 lbs	340 kg	4.58	19 Gal.	71.9 L	★
WATER-COOLED	IRT0900W	regular	748 lbs	339 kg	665 lbs	302 kg	4.04	19 Gal.	71.9 L	NA
	IDT0900W	dice	780 lbs	354 kg	665 lbs	302 kg	4.02	19 Gal.	71.9 L	NA
	IYT0900W	half-dice	722 lbs	327 kg	665 lbs	302 kg	4.02	19 Gal.	71.9 L	NA

* Water-cooled Condenser Water Usage / 100 lbs. /45.4 kgs. Of Ice: 135 gal / 511 L.
* Water-cooled models are excluded from ENERGY STAR qualification.

Accessories

LuminIce® II Growth Inhibitor
reduces yeast and bacteria growth for a cleaner ice machine.



External Scoop holder

Protect the ice scoop with the NSF approved versatile scoop holder.

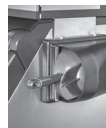

Arctic Pure® Water Filters

Reduces sediment and chlorine odors for better tasting ice.



iAuCS®
schedules and performs routine ice machine cleaning automatically.

